



Note on instructions

These instructions contain the information required for using the LOCA-proof limit switch in accordance with its intended purpose. They are addressed to technically qualified personnel. The instructions provide a summary of the most important safety measures and must be read by everyone working with the product so that they will be familiar with the correct handling of the product. The instructions have to be kept for future reference and must be available throughout the expected life of the product.

Description

The LOCA limit switches in this series are metal-encapsulated precision switches in a robust compact construction. The connection is made either by a plug (Harting 7D) or a connection lead with cable gland (SR-SV-M 20, clearance depending on cable). The integrated basic switch is a single-pole changeover contact with a high switching accuracy and precise reproducibility of the switching point.

Switching unit LOCA-proof conditions of use

Ambient temperature

-25 °C to +85 °C (-13 °F to +185 °F)

Accident conditions

Radiation resistances up to 800 kGy:

$\vartheta_{max.} = 156 \text{ °C}/12 \text{ h}$

$p_{max.} = 7.0 \text{ bar abs.}$

Radiation resistances up to 250 kGy:

$\vartheta_{max.} = 152 \text{ °C}/24 \text{ h}$

$p_{max.} = 5.5 \text{ bar abs.}$

Radiation exposure

Under normal conditions: 50 kGy

Technical data

Snap-action switch

Contacts Ag/Ni gold-plated, Inert gas N2

Switching capacity

$P_{max.} = 35 \text{ W}$ at $L/R \leq 10 \text{ ms}$

Voltage, currents

$U_B = \text{DC } 60 \text{ V}$

$U_{max.} = \text{DC } 115 \text{ V}$

$I_{max.} = 2.5 \text{ A}$

Dielectric strength

Contact - ground: 1500 V

Contact - contact: 500 V/5 s

Insulation resistance

at ϑ_a : $> 100 \text{ M}\Omega$ (at ambient temperature)

at LOCA: 60 k Ω / contact - contact

Measuring voltage: 100 V

Weight

approx. 700 g

Tightening torques

Fastening screws: max. 8 Nm

Enclosure/actuator material

Red bronze, Stainless steel, FKM, PPS, EPDM

Dimensions

see ff.

Actuator

Technical data

Contact travel roller lever 32 mm

Actuating force in the operating position: max. 12 N

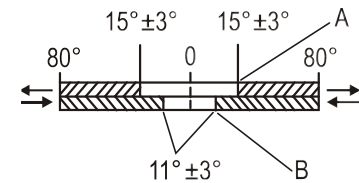

A = operating position

B = release position

Contact travel roller lever 17 mm

Actuating force in the operating position: max. 22 N

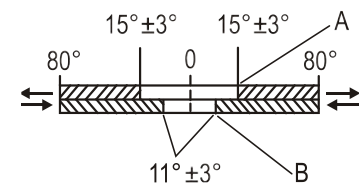

A = operating position

B = release position

Contact travel roller plunger

Actuating force in the operating position: max. 26 N
Actuating force end overtravel: max. 49 N

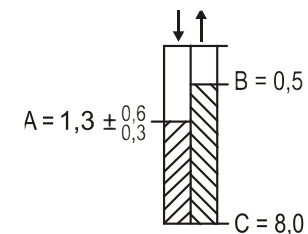

A = operating position [mm]

B = min. release position [mm]

C = max. travel [mm]

Mechanical characteristics

Switching rate

max. 100/min

Mechanical service life

at least 20 000 actuations

Vibration resistance

> 20 g (20 to 120 Hz)



Safety Instructions

The limit switch with fitted actuator is a safety component. Incorrect installation can cause it to malfunction. Only authorized and qualified personnel may do the engineering and any of the assembly, disassembly, installation, commissioning, maintenance, and fault clearance work. Utilization in areas other than those specified or the alteration of the product by anyone other than the manufacturer will exempt BARTEC from liability for defects and any further liability. The generally applicable statutory rules and other binding guidelines relating to workplace safety, accident prevention and environmental protection must be adhered to. The limit switch may be operated if it is clean and in undamaged condition. The limit switch may not be used as a mechanical stop and may never be operated without an actuating element. The switch must be replaced after any short-circuit that occurs in the main circuit because the switch is a piece of encapsulated equipment and it is therefore not possible to check the state of the switch contacts

Marking

Particularly important points in these instructions are marked with a symbol:

DANGER

DANGER indicates a hazardous situation which, if not avoided, will result in death or serious injury.

WARNING

WARNING indicates a hazardous situation which, if not avoided, could result in death or serious injury.

CAUTION

CAUTION indicates a hazardous situation which, if not avoided, could result in minor or moderate injury.

NOTICE

NOTICE is used to address practices not related to personal injury.

NOTE

Important instructions and information on effective, economical and environmentally compatible handling.

Standards conformed to

- EN 50041 A1 (only roller levers)
- EN 50041 C1 (only roller plunger)

Tests

Tests based on AREVA test program PTCQ-G/2013/en/1032, Rev. C

Transport and Storage

NOTE

Transport and storage is permissible in original packaging only. The limit switch has to be stored under dry conditions at temperature from -10 °C up to +40 °C inside buildings.

Assembly, Installation and Commissioning

NOTICE

Elevated ambient temperature through heat radiation!

Attention must be paid during assembly that radiation or convection heat does not give rise to temperatures that exceed maximum continuous service temperature.

Assembly/disassembly

NOTICE

If the limit switches/actuators are stored in a cold environment, condensation may occur at the site of installation!

- Only components without condensation may be fitted.
- The limit switch must be fitted in a way that ensures protection against impact energy.

Check when assembling:

- Fasten the limit switch with M5 stainless steel screws (recommended tightening torque = 8 Nm). Both socket-head cap screws (Inbus/Allen) and hexagonal screws can be used.
- The screwed connection must be produced to be vibration-proof (fixing with adhesive or ratchet disks).
- It is recommended to report the type and manufacturing number of the limit switch in the system documentation with measuring circuit.

Installation

NOTICE

Faulty electrical connections!

- Select the supply cable so that it satisfies the electrical, thermal, radiological and mechanical requirements in the area of application.
- Do not damage the individual cores during installation

Check when installing:

- Prepare fine-stranded and multi-stranded conductors. Crimp wire end sleeves with suitable crimping tools.

Commissioning

Before commissioning check that:

- The limit switches have been installed in compliance with regulations
- The limit switch is not damaged
- There is no foreign matter obstructing the actuating travel
- The connection has been established properly
- All screws and nuts have been tightened securely

Operation

NOTICE

Malfunction in power plant operation!

- The limit switch may be operated only within the technical limits that apply to it (see also "Technical data").

Maintenance and Fault Clearance

WARNING

Improper maintenance/repair!

Only authorized qualified personnel may do any of the work relating to maintenance and fault clearance.

Maintenance

WARNING

Improper lubricant!

- In limit switches with roller plunger, the "BARRIERTA L55/2" lubricant is used between the plunger and the bushing.
- For relubrication, apply exclusively a thin film of "BARRIERTA L55/2" lubricant.

The lubricant between the plunger and the bushing must be checked in the course of the periodical inspection. See "Relubricate the actuator with roller plunger" for illustrations of the lubrication procedure.

NOTE

In limit switches with roller lever, the lubricant is only used in sealed enclosures. Visual controls are not required.

The operator of the limit switch must keep it in an orderly condition, operate it correctly, monitor it and clean it regularly.

- Test limit switches for correct functioning regularly. The plant operator has to define the inspection intervals according to the intended application.
- Check the limit switch enclosure and plug/cable gland regularly for damage and dirt.

NOTE

Dirty enclosures/actuators can be cleaned with compressed air.



Fault Clearance

The limit switch is defective:

- if switching functions are no longer possible with the switching unit
- if the actuator does not activate the switching unit any longer
- or if the actuator moves in a strongly damped way

The user cannot repair defective limit switches. They must be replaced considering this operational instruction. If necessary, defective limit switches can be repaired in the manufacturing plant.

Accessories, Spare Parts

For accessories and spare parts, contact the firm of BARTEC GmbH at the service address.

Disposal

The components in the limit switch contain metal and plastic parts. Therefore the statutory requirements for disposing of electronic scrap must be observed (e. g. disposal by an approved disposal company).

Service Address

BARTEC GmbH
 Max-Eyth-Str. 16
 97980 Bad Mergentheim
 Germany
 Phone: +49 7931 597 0
 Fax: +49 7931 597 119

Relubricate the actuator with roller plunger

NOTICE

Loss of the roller axis!

A retaining ring (a) secures the roller axis (b). When moving the retaining ring, take care not lose the roller axis.

NOTE

Regular relubricating replaces complete lubricating.

1. Press down the retaining ring until the spring goes solid.

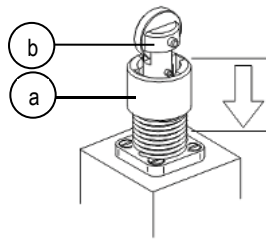

2. Apply a thin film of "BARRIERTA L55/2" lubricant (manufacturer: Klüber lubrication, material no. 090013) along the entire circumference between the top edge of the bushing and the plunger.

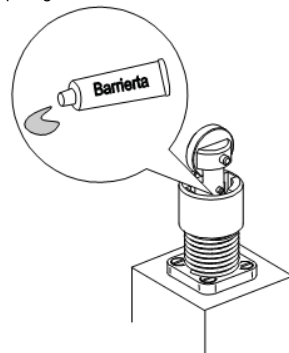

3. Release the retaining ring carefully. Take care that the retaining ring is not twisted and that the retaining ring properly locks into place in the roller plunger.

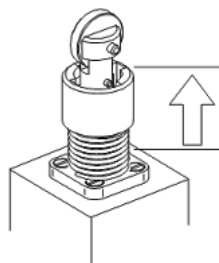



Lubricating the actuator with roller plunger

NOTICE

Loss of the roller axis!

A retaining ring (a) secures the roller axis (b). When moving the retaining ring, take care not lose the roller axis.

NOTE

The capital letters indicate the order of disassembly. The roller plunger is assembled in reverse order. Screw in slotted screws to finger-tightness only (approx. 3 Nm).

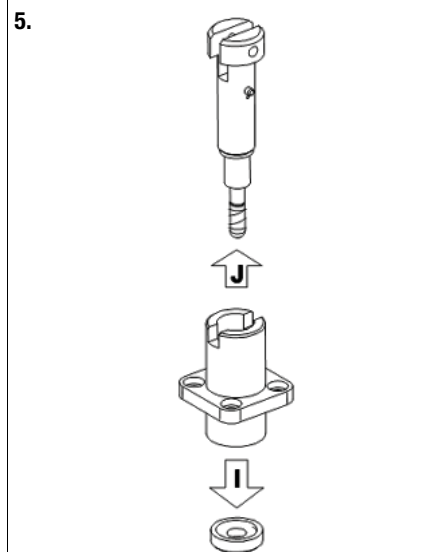
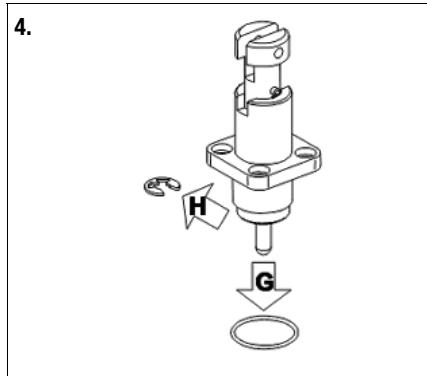
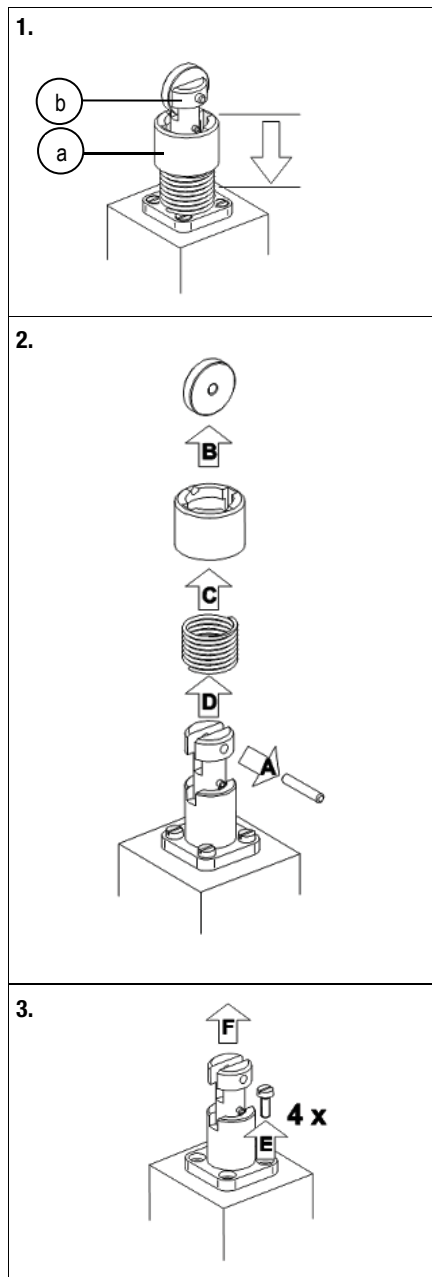

NOTICE

When disassembly and assembly take care of a proper handling of the O-ring.

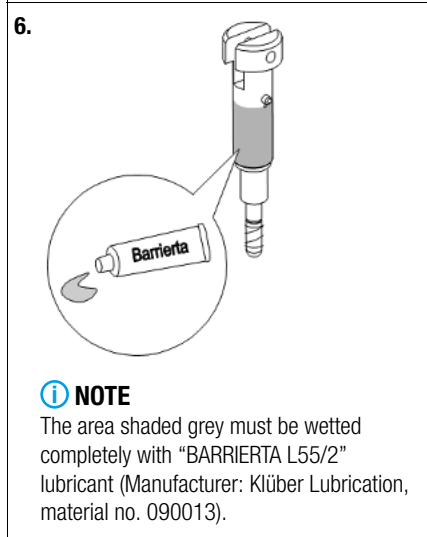

NOTE

The area shaded grey must be wetted completely with "BARRIERTA L55/2" lubricant (Manufacturer: Klüber Lubrication, material no. 090013).



Dimensions

NOTE

Include the bending radius for the connection cable in the planning.

Type 37-2917-1130/35..

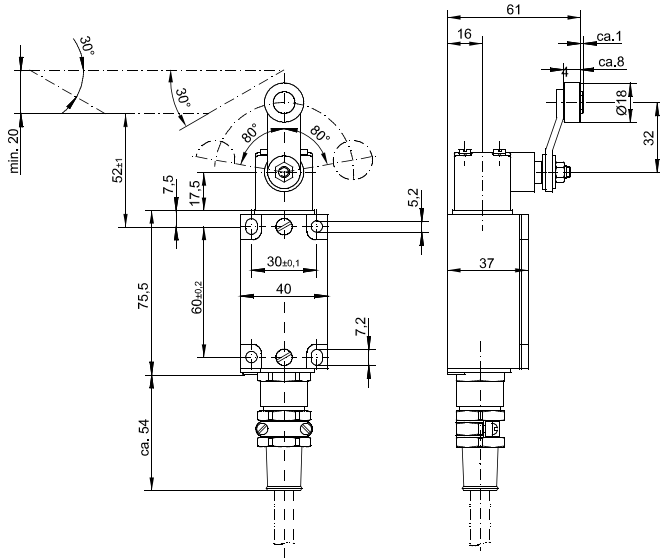

Type 37-2917-1130/A5..

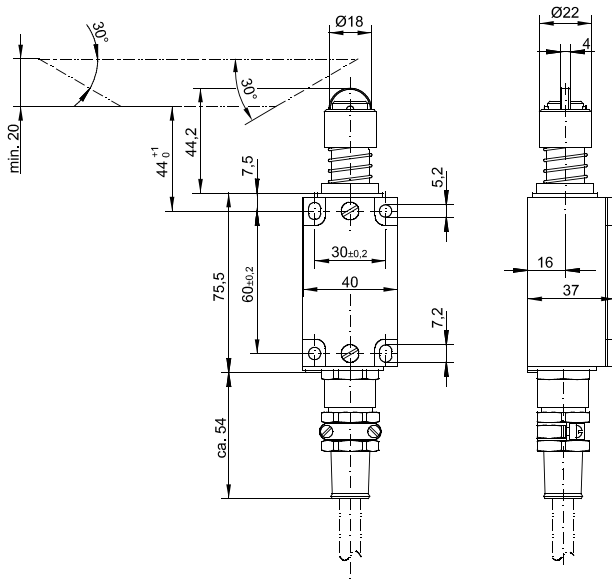

Versions of limit switches with connection cable

NOTE

This table gives an overview of the available actuators and the switching functions as well as information about the type key structure.

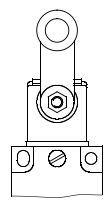
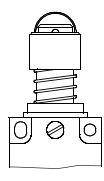
x	= actuator, 37-2917-1130/x5yy
3	Roller lever 32 mm 
A	Roller plunger with additional spring 

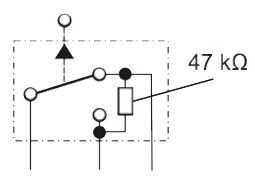
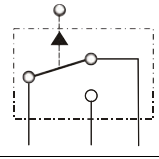
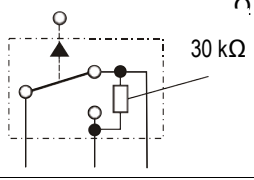
yy	= switching function 37-2917-1130/x5yy
01	with open-circuit resistance, colour code depending on conductor 
02	without open-circuit resistance, colour code depending on conductor 
E5	with open-circuit resistance, colour code depending on conductor 



Dimensions

NOTE

Include the bending radius for the connection cable in the planning.

Type 37-2937-1130/35..

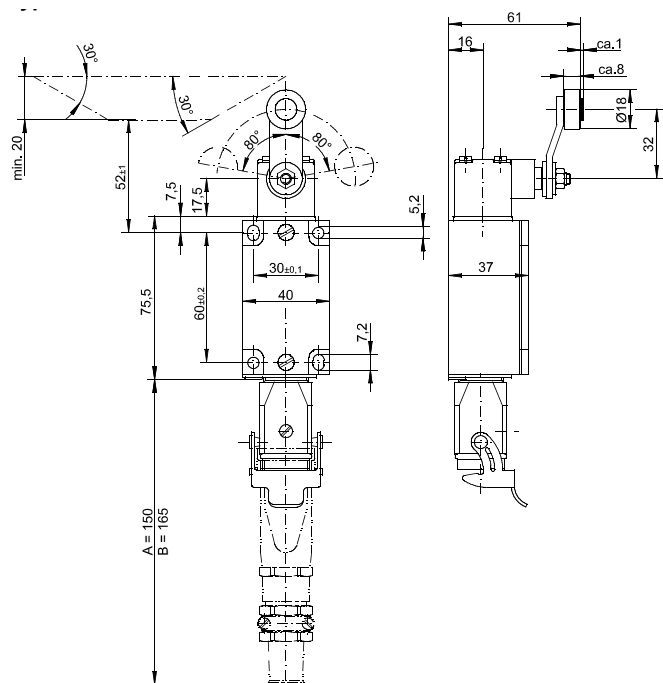

Type 37-2937-1130/A5..

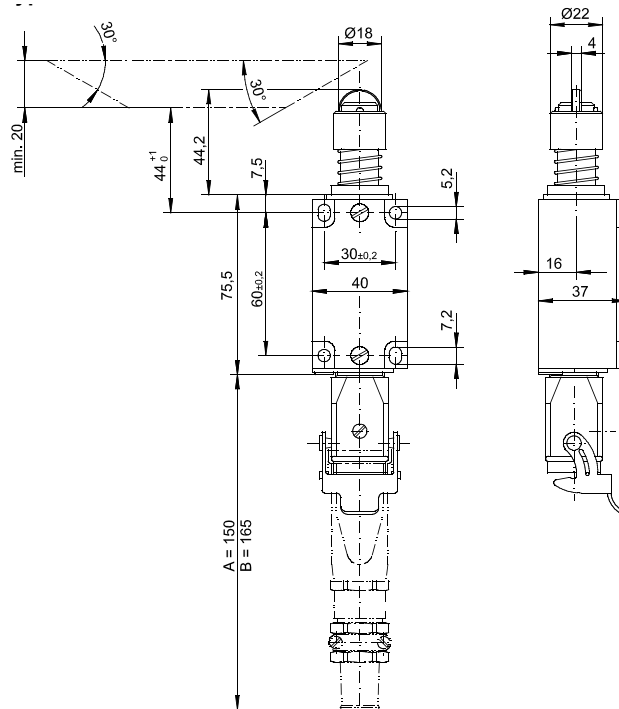

Type 37-2937-1130/B5..

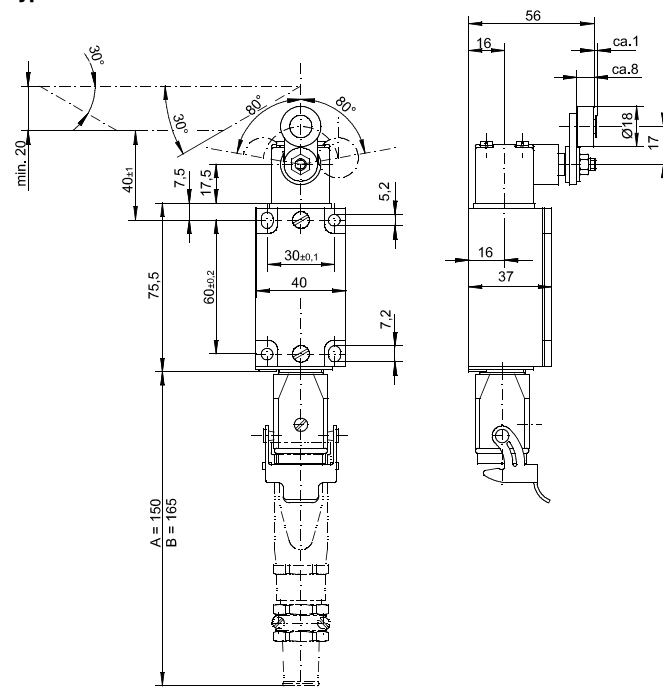

31-2917-7D0001/C-07/2017-BCS-362340

Reservation Technical data subject to change without notice. Changes, errors and misprints may not be used as a basis for any claim for damages.



Versions of limit switches with plug connection

NOTE

The following tables give an overview of the available actuators and the switching functions as well as information about the type key structure.

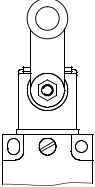
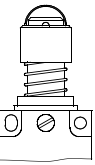
x	= actuator, 37-2937-1130/x5yy
3	Roller lever 32 mm 
A	Roller plunger with additional spring 

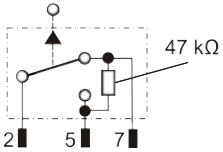
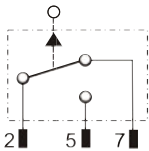
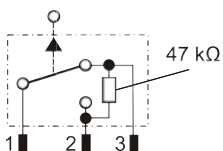
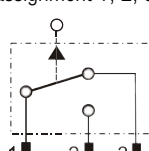
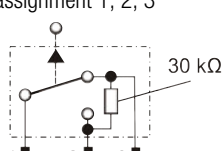
yy	= switching function, 37-2937-1130/x5yy
02	with open-circuit resistance, contact assignment 2, 5, 7 
03	without open-circuit resistance, contact assignment 2, 5, 7 
E2	with open-circuit resistance, contact assignment 1, 2, 3 
E3	without open-circuit resistance, contact assignment 1, 2, 3 
E4	with open-circuit resistance, contact assignment 1, 2, 3 

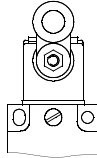
B	= actuator, 37-2937-1130/B5yy Roller lever 17 mm 
----------	--

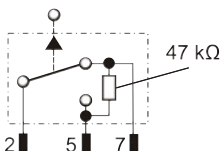
yy	= switching functions, 37-2937-1130/B5yy
02	with open-circuit resistance, contact assignment 2, 5, 7 
03	without open-circuit resistance, contact assignment 2, 5, 7 