

Amphenol® Star-line Ex® Assembly Instructions

(Applies to ATEX, IECEx and AEX product, with special attention to marking)

L-2120-3



Document Contents:

- Familiarization & Assembly Information
- Contact Assembly & Termination
 - Mixing Instructions
 - Potting Instructions

For additional information, consult Amphenol Industrial Power Connectors, 12-054-4

©Amphenol EEC, Des Plaines,
IL, USA

Amphenol Industrial

Printed in U.S.A.
Revision N, 03/18/2022

Description of equipment

The Star-line EX series of connectors is comprised of metallic bodied plug and receptacle shells, to form in-line cable connections. Externally the main bodies are fitted with suitably certified cable glands. Internally the main bodies each contain an insulator insert fitted with solder or pressure type contacts of either a pin or socket variety. The plug and receptacle shells together form an in-line connector. When connected together they form a spigotted flamepath and are mechanically interlocked by means of a threaded nut retained by a grub screw.

Additionally, the receptacle connector is available in a bulkhead mounted version that contains an externally threaded flamepath for mounting to certified EX enclosures with suitable internal mating thread. This variety of bulkhead mount connector, must be internally potted, as described within this document.

The range is comprised of seven body (forms) sizes, each with a number of pin/socket size combinations between 1 and 143 contacts. The connector shell size, pin configuration and rating are reflected in the individual type designations.

Design Option are described below and include, alternative keying options, and pin or sleeve contacts in either the plug or receptacle bodies.

Connectors are certified IP66 and IP68.

For 2 conductors into 1 contact, please refer to drawing AOGT-2TO1

Part Number Code Logic: EX(a) - (b) - (c) - (d)- (e) - (f)(g)(h)(j) - (k)

Connector series type designation	EX
Shell material (a)	Aluminum (default, omit code) B- Brass S-Stainless steel
Shell configuration (b)	13- Inline Plug, w/ accompanying blanking cap. 15- Inline Receptacle, w/ accompanying blanking cap. 17 - Flange Mount Receptacle, w/ accompanying blanking cap. 17-H- Hermetic Flange Mount Receptacle, w/ accompanying blanking cap & potting adapter (requires potting). 18 - Circular Bulkhead Mount Receptacle, w/ accompanying blanking cap. 18-H6 – Hermetic Circular Bulkhead Mount Receptacle 6 hole, w/ accompanying blanking cap & potting adapter (requires potting). 18-H8 - Hermetic Circular Bulkhead Mount Receptacle 8 hole, w/ accompanying blanking cap & potting adapter (requires potting). 19-H – Hermetic Circular Bulkhead Feed Thru Mount Receptacle with Locking Jam Nut, accompanying blanking cap & potting adapter (requires potting).
Cable Adapter style (c)	1 – Bulkhead Mount (w/ potting adapter; requires potting) 2 – Mechanical Clamp (requires potting) 3 – Threaded for use with EX certified Gland 4 – Basketweave Grip (requires potting) 9 – 90° Adapter
Grommet ID (d)	See catalog for available sizes and codes
Shell Size (e)	12, 16, 20, C20, 24, C24, 28, C28
Contact Insulation (f)	See catalog for configurations
Contact Gender (g)	P - Pin, S - Socket
Termination Style (h)	N- Crimp, R- Pressure
Insert Rotation (j)	Normal (default, omit code) For alternates, refer to catalog
Planned Additions (k)	Certified Variations

Familiarization & Assembly Information

1. Read manufacturer's assembly instructions before actually starting to assemble connectors. Besides the matter of instruction on correct procedures, there are two important reasons for this preliminary step: To identify the various component parts, and to check for any missing parts.
2. Cut cable jacket and sheathing squarely and sheathing squarely and to correct length, using only wire strippers that have been approved for the operation. In preparing the individual wires in cables and harnesses for assembly, make allowances in length for reaching the outer most circle of contacts cavities in the conductors. The insulation should be cut progressively longer as they extend out from the center of the cable or harness to assure sufficient length.
3. Follow chart on Page 11 covering maximum cable stripping lengths for effective cable gland sealing. All conductors should be fit into contact wire wells correctly. A practice layout should be done so that an assembler can oversee what the finished will look like when finished.
4. Before starting actual termination of wires, it is essential that cables and harnesses be laid out in a specific order in accordance with the wiring diagram. Proper layout will eliminate the need for twisting and crossover of conductors. If the wiring layout is not correct, the termination operation will be difficult or even impossible and the chances for making errors will be increased. Cable and harness assemblies having a spiral layout must also be matched carefully to the correct contacts in both the male and female inserts.
5. Some cables that will be used will have a "basket weave" type of armor under the outer jacket (sheath) and over the inner jacket. Since many regulatory entities require that the armor be grounded at least at the source end, it is beneficial to ground the armor via a spare contact within the connector. Follow the removal of sufficient amount of outer jacket (see chart on Page 11). Ample amount of armor can be clipped away, but not all. An adequate amount should remain in order that a small cross-section conductor, short in length, be woven into the remaining armor weave and either soldered or covered with mastic impregnated heat shrink, creating an intimate bond to the armor. At the opposite end of the short piece of wire a contact should be crimped and inserted into the insert.
6. Use only correctly sized and ingress protected certified glands provided to assure resistance to moisture and other contaminates.
7. Use only the proper crimping tools that have been set or calibrated with precision gages.
8. Make certain that all contacts are the correct size before attempting to assemble in insert cavities. This point is particularly important when both power and control types of contacts are used in the same connector.
9. Be sure that any ground contacts (when applicable) are correctly located.
10. Seat all contacts properly so that they will not be damaged or become disengaged during connectors mating operation.
11. Use only the proper insertion tools and be sure that they are aligned axially when pushing contact into their fully seated position.
12. When inserts have more cavities than the conductors, plug unused cavities with furnished contacts.
13. After all terminated contacts are inserted in their respective cavities and inspected (detailed on page 13), the cable adapter should be installed and tightened with a strap wrench (detailed on page 12).
14. When handling cables, use adequate support to prevent damage to the internal wires. Exd glands are intended for sealing purposes and should not be used as a cable grip.
15. If for any reason, terminated conductors have to be removed from an insert because of an assembly error or change in circuitry, be sure to remove the cable gland or cable adapter first before extracting the contact and re-inserting it.
16. If one of the connector poles is a ground wire, make sure that it is grounded properly before the connector actually is engaged.
17. When connectors have the same configuration are to be mounted closer together, different or alternate key arrangements should be used to prevent mismatching and possible damage to the electrical system.
18. Always inspect all aspects of connector assembly operations before putting connector into actual operation.
19. Crimping and terminating of conductors to contacts must be done carefully. Make certain that all wire strands are fully bottomed in contact wells by checking through inspection hole provided (detailed on page 13).
20. Never try to straighten bent contacts. Straightening cannot be done properly and the plating on contacts very likely will be marred. This will result in a high resistance connection and will expose the base material to possible corrosion.
21. Each assembly operator should be his own inspector. Worn, damaged, or defective tools should be reported immediately to foreman and supervisors. Assembly operators should be indoctrinated with this attitude and made to understand the importance of always guarding quality. Assembly workmanship is significant factor in terminating the quality of multiple contact connectors. Quality cannot be "inspected" into connectors; it must be "built-in" during each and every assembly operation.

Star-Line EX® Cable Types

It is the responsibility of the specifier/user to select the appropriate cable to be used with the EX Star-Line connector system. The specifier/user should favor the use of cables constructed with flexible conductors (IEC class 5 or higher/ICEA type H or higher) as well as a flexible armor type (basket weave) if required. Armor systems such as those identified in IEC 92-3 or IEEE455 or UL1309 are recommended. An impervious jacket should always be furnished over the armor. IEC/ BS cables such as armored with SWA (X), tape(Z), and NEC style cables such as 'interlocked' or MC are not recommended with the EX connector system.

The armor system should be grounded at the source point. Periodically the specifier/user should investigate the need for armor grounding (earthing) within the plug or in-line connector or itself. In addition to the weaving of the armor grounding conductor, soldering and/or heat shrink and/or strong adhesive electrical takes, and/or 'tension banding' should be applied on the armor and conductor to insure a permanent bond. The armor grounding wire should be terminated (solder or crimp) to an appropriate sized contact, and inserted into the connector insert.

The armor system should not be confused or associated with shielding which is employed with instrumentation/telecommunication cables. Shielding for pairs/triads have their own individual drain wires which should be terminated onto dedicated contacts. These drain wires should be insulated with heat shrink within the connector body to prevent contact with other drain wires or pair/triad shield faces.

The above procedure does not apply to single conductor cables, i.e., 444-1111mcm (150mm-500mm), or multi-conductor power or control cables.

Single conductor Cables Periodically single conductor cables will be required in an armored and sheathed construction.

Since there is no armor grounding contact path provided within the connector assembly, a suitable external method must be employed. It is recommended that a small strip of outer jacket be cut away a reasonable distance from the entrance to the cable gland of the connector. A durable insulated conductor with a cross section not smaller than #14awg/4mm should be bonded to the exposed armor. Protective tapes or heat or cold shrink (3M PST) should be applied to protect this bonding point. The opposite end of this grounding conductor should be terminated at the corresponding receptacles' panel via one of the receptacles' fastening screws or a dedicated grounding lug or bar. In an 'in-line' configuration, a mirror image of the above should be used with a simple mating point in close proximity to the connector set.

In summary the specifier/user should be versed in acceptable applications that are allowed by the regulatory/certifying bodies having jurisdiction. Periodic inspection of this grounding arrangement should be implemented.

All connectors are furnished with a protective cover. In actuality this cover is viewed as a critical part of the connector. The cover is compared to a cover on a flameproof (Exd) enclosure. Absence of the cover voids the Ex certification. The covers should not be viewed as an incidental protection to the external elements, but a required component of a hazardous certified device. When the connectors are plugged together the covers can be screwed into each other to protect the threads from damage. When the connectors are not mated, it is required that the covers be installed and the set screws on the covers be fully driven into the body of the connector. Replacement covers and 'NYLOK' set screws are available on request.

ATEX/IECEX Product Labeling Information

Information below must be attached to connectors via non-removable label.

Amphenol EEC
Des Plaines IL 60018

USA Star-Line, Size

Ref

Work Order Number; Date Code; Facility Code

XXXX

II 2 GD



IP66

IP68-8



DO NOT SEPARATE WHEN ENERGIZED

See charts starting on page 5 for labeling detail

ATEX Certificate Number & IECEx Certificate Number

"Max volts, Max amp, Current rating per pin"

TABLE 1: LABEL MARKING - ATEX/IECEX PRODUCT LABELING

CONNECTOR STYLE	DESCRIPTION	AMBIENT TEMP (°C)	HAZARDOUS LOCATION MARKING	ADDITIONAL MARKING FOR FIBER OPTIC MODELS (INSERT AFTER 2ND LINE OF STANDARD MARKING)	AMPERAGE RESTRICTIONS	CABLE/COND RATING (MIN TEMP)	CEMENT
13-2, 15-2, 17-2, 13-4, 15-4, 17-4	MECH. CLAMP W/ CEMENT OR BAS- KETWEAVE CABLE GRIPS	-40 TO +40	[EPSILON MARK] II 2 G D Ex db IIC T6 Gb Ex tb IIIC T80°C Db IP66/68	Ex op pr IIC T6 Gb (-40°C to +40°C) Ex op is IIC T6 Gb (-40°C to +40°C)	0-259A SEE NOTES A-D	90°C	10-838535-(-)
		-40 TO +55	[EPSILON MARK] II 2 G D Ex db IIC T5 Gb Ex tb IIIC T95°C Db IP66/68	Ex op pr IIC T5 Gb (-40°C to +55°C) Ex op is IIC T4 Gb (-40°C to +55°C)	0-408A SEE NOTES A-D	90°C	10-838535-(-)
		-40 TO +55	[EPSILON MARK] II 2 G D Ex db IIC T4 Gb Ex tb IIIC T130°C Db IP66/68	-----	0-1135A SEE NOTES A-D	135°C	10-838535-(-)
		-40 TO +40	[EPSILON MARK] II 2 G D Ex db IIC T6 Gb Ex tb IIIC T80°C Db IP66/68	Ex op pr IIC T6 Gb (-40°C to +40°C) Ex op is IIC T6 Gb (-40°C to +40°C)	0-259A SEE NOTES A-D	90°C	10-838535-(-)
13-3, 15-3, 17-3	EX GLAND (NO CE- MENT)	-40 TO +55	[EPSILON MARK] II 2 G D Ex db IIC T5 Gb Ex tb IIIC T95°C Db IP66/68	Ex op pr IIC T5 Gb (-40°C to +55°C) Ex op is IIC T4 Gb (-40°C to +55°C)	0-408A SEE NOTES A-D	90°C	10-838535-(-)
		-40 TO +55	[EPSILON MARK] II 2 G D Ex db IIC T4 Gb Ex tb IIIC T130°C Db IP66/68	-----	0-1135A SEE NOTES A-D	135°C	10-838535-(-)
		-40 TO +40	[EPSILON MARK] II 2 G D Ex db eb IIC T6 Gb Ex tb IIIC T80°C Db IP66/68	Ex op pr IIC T6 Gb (-40°C to +40°C) Ex op is IIC T6 Gb (-40°C to +40°C)	0-259A SEE NOTES A-D	90°C	10-838535-(-)
17-1	17-1 PANEL MT SQ. FLANGE W/ POT- TING ADAPTER AND CEMENT.	-40 TO +55	[EPSILON MARK] II 2 G D Ex db eb IIC T5 Gb Ex tb IIIC T95°C Db IP66/68	Ex op pr IIC T5 Gb (-40°C to +55°C) Ex op is IIC T4 Gb (-40°C to +55°C)	0-408A SEE NOTES A-D	90°C	10-838535-(-)
		-40 TO +55	[EPSILON MARK] II 2 G D Ex db eb IIC T4 Gb Ex tb IIIC T130°C Db IP66/68	-----	0-1135A SEE NOTES A-D	135°C	10-838535-(-)
		-20 TO +40	[EPSILON MARK] II 2 G D Ex db eb IIC T6 Gb Ex tb IIIC T80°C Db IP66/68	Ex op pr IIC T6 Gb (-20°C to +40°C) Ex op is IIC T6 Gb (-20°C to +40°C)	0-259A SEE NOTES A-D	90°C	10-718000-(-) HYSOL
18-1	18-1 CIRCULAR FLANGE W/ POT- TING ADAPTER AND CEMENT	-40 TO +40	[EPSILON MARK] II 2 G D Ex db eb IIC T6 Gb Ex tb IIIC T80°C Db IP66/68	Ex op pr IIC T6 Gb (-40°C to +40°C) Ex op is IIC T6 Gb (-40°C to +40°C)	0-259A SEE NOTES A-D	90°C	10-838535-(-)
		-40 TO +55	[EPSILON MARK] II 2 G D Ex db eb IIC T5 Gb Ex tb IIIC T95°C Db IP66/68	Ex op pr IIC T5 Gb (-40°C to +55°C) Ex op is IIC T4 Gb (-40°C to +55°C)	0-408A SEE NOTES A-D	90°C	10-838535-(-)
		-40 TO +55	[EPSILON MARK] II 2 G D Ex db eb IIC T4 Gb Ex tb IIIC T130°C Db IP66/68	-----	0-1135A SEE NOTES A-D	135°C	10-838535-(-)

Note A: When using cables with 3 conductors or less: Amperage always limited to shell size and never greater than 1135A in any case

Note B: When using cables with 3 conductors or more: Maximum current is derated according to NEC Table 310.15(B)(3)(a).

Note C: Amperage restriction is based on single pin configuration and used for derating according to cable temperature and ambient temperature.

Note D: Connectors intended as part of a mated pair: Amperage to be derated to that of the one with a lower value.

TABLE 2: LABEL MARKING - ATEX/IECEX PRODUCT LABELING

CONNECTOR STYLE	DESCRIPTION	AMBIENT TEMP (°C)	HAZARDOUS LOCATION MARKING	ADDITIONAL MARKING FOR FIBER OPTIC MODELS (INSERT AFTER 2ND LINE OF STANDARD MARKING)	AMPERGE RESTRICTIONS	CABLE/COND RATING (MIN TEMP)	CEMENT
13-9	90° BACKSHELL WITH EX GLAND NO CEMENT	-40 TO +40	[EPSILON MARK] II 2 G D Ex db IIC T6 Gb Ex tb IIIC T80°C Db IP66/68	----	0-259A SEE NOTES A-D	90°C	10-838535-(-)
		-40 TO +55	[EPSILON MARK] II 2 G D Ex db IIC T5 Gb Ex tb IIIC T95°C Db IP66/68	----	0-408A SEE NOTES A-D	90°C	10-838535-(-)
		-40 TO +55	[EPSILON MARK] II 2 G D Ex db IIC T4 Gb Ex tb IIIC T130°C Db IP66/68	----	0-1135A SEE NOTES A-D	135°C	10-838535-(-)
		-40 TO +55	[EPSILON MARK] II 2 G D Ex db IIC T3 Gb Ex tb IIIC T195°C Db IP66/68	----	0-1135A SEE NOTES A-D	135°C	10-838535-(-)
13-91	90° BACKSHELL NO ADAPTERS, WITH CEMENT	-40 TO +40	[EPSILON MARK] II 2 G D Ex db eb IIC T6 Gb Ex tb IIIC T80°C Db IP66/68	----	0-259A SEE NOTES A-D	90°C	10-718000-(-) HYSOL
		-40 TO +55	[EPSILON MARK] II 2 G D Ex db eb IIC T5 Gb Ex tb IIIC T95°C Db IP66/68	----	0-408A SEE NOTES A-D	90°C	10-838535-(-)
		-40 TO +55	[EPSILON MARK] II 2 G D Ex db eb IIC T4 Gb Ex tb IIIC T130°C Db IP66/68	----	0-408A SEE NOTES A-D	90°C	10-838535-(-)
		-40 TO +55	[EPSILON MARK] II 2 G D Ex db eb IIC T4 Gb Ex tb IIIC T195°C Db IP66/68	----	0-1135A SEE NOTES A-D	135°C	10-838535-(-)

Note A: When using cables with 3 conductors or less: Amperage always limited to shell size and never greater than 1135A in any case

Note B: When using cables with 3 conductors or more: Maximum current is derated according to NEC Table 310.15(B)(3)(a).

Note C: Amperage restriction is based on single pin configuration and used for derating according to cable temperature and ambient temperature.

Note D: Connectors intended as part of a mated pair: Amperage to be derated to that of the one with a lower value.

TABLE 3: LABEL MARKING - ATEX/IECEX PRODUCT LABELING – “AR” (ARCTIC RANGE) PRODUCT

CONNECTOR STYLE	DESCRIPTION	AMBIENT TEMP (°C)	HAZARDOUS LOCATION MARKING	ADDITIONAL MARKING FOR FIBER OPTIC MODELS (INSERT AFTER 2ND LINE OF STANDARD MARKING)	AMPERAGE RESTRICTIONS	CABLE/COND RATING (MIN TEMP)	CEMENT
13-2, 15-2, 17-2, 13-4, 15-4, 17-4	MECH. CLAMP W/ CEMENT OR BAS- KETWEAVE CABLE GRIPS	-60 TO +40	[EPSILON MARK] II 2 G D Ex db IIC T6 Gb Ex tb IIIC T80°C Db IP66/68	Ex op pr IIC T6 Gb (-60°C to +40°C) Ex op is IIC T6 Gb (-60°C to +40°C)	0-259A SEE NOTES A-D	90°C	10-838535(-)
-60 TO +55		[EPSILON MARK] II 2 G D Ex db IIC T5 Gb Ex tb IIIC T95°C Db IP66/68	Ex op pr IIC T5 Gb (-60°C to +55°C) Ex op is IIC T4 Gb (-60°C to +55°C)	0-408A SEE NOTES A-D	90°C	10-838535(-)	
-60 TO +55		[EPSILON MARK] II 2 G D Ex db IIC T4 Gb Ex tb IIIC T130°C Db IP66/68	----	0-1135A SEE NOTES A-D	135°C	10-838535(-)	
13-3, 15-3, 17-3	EX GLAND (NO CE- MENT)	-60 TO +40	[EPSILON MARK] II 2 G D Ex db IIC T6 Gb Ex tb IIIC T80°C Db IP66/68	Ex op pr IIC T6 Gb (-60°C to +40°C) Ex op is IIC T6 Gb (-60°C to +40°C)	0-259A SEE NOTES A-D	90°C	10-838535(-)
-60 TO +55		[EPSILON MARK] II 2 G D Ex db IIC T5 Gb Ex tb IIIC T95°C Db IP66/68	Ex op pr IIC T5 Gb (-60°C to +55°C) Ex op is IIC T4 Gb (-60°C to +55°C)	0-408A SEE NOTES A-D	90°C	10-838535(-)	
-60 TO +55		[EPSILON MARK] II 2 G D Ex db IIC T4 Gb Ex tb IIIC T130°C Db IP66/68	----	0-1135A SEE NOTES A-D	135°C	10-838535(-)	
17-1	17-1 PANEL MT SQ. FLANGE W/ POT- TING ADAPTER AND CEMENT.	-60 TO +40	[EPSILON MARK] II 2 G D Ex db eb IIC T6 Gb Ex tb IIIC T80°C Db IP66/68	Ex op pr IIC T6 Gb (-60°C to +40°C) Ex op is IIC T6 Gb (-60°C to +40°C)	0-259A SEE NOTES A-D	90°C	10-838535(-)
-60 TO +55		[EPSILON MARK] II 2 G D Ex db eb IIC T5 Gb Ex tb IIIC T95°C Db IP66/68	Ex op pr IIC T5 Gb (-60°C to +55°C) Ex op is IIC T4 Gb (-60°C to +55°C)	0-408A SEE NOTES A-D	90°C	10-838535(-)	
-60 TO +55		[EPSILON MARK] II 2 G D Ex db eb IIC T4 Gb Ex tb IIIC T130°C Db IP66/68	----	0-1135A SEE NOTES A-D	135°C	10-838535(-)	
18-1	18-1 CIRCULAR FLANGE W/ POT- TING ADAPTER AND CEMENT	-60 TO +40	[EPSILON MARK] II 2 G D Ex db eb IIC T6 Gb Ex tb IIIC T80°C Db IP66/68	Ex op pr IIC T6 Gb (-60°C to +40°C) Ex op is IIC T6 Gb (-60°C to +40°C)	0-259A SEE NOTES A-D	90°C	10-838535(-)
-60 TO +55		[EPSILON MARK] II 2 G D Ex db eb IIC T5 Gb Ex tb IIIC T95°C Db IP66/68	Ex op pr IIC T5 Gb (-40°C to +55°C) Ex op is IIC T4 Gb (-40°C to +55°C)	0-408A SEE NOTES A-D	90°C	10-838535(-)	
-60 TO +55		[EPSILON MARK] II 2 G D Ex db eb IIC T4 Gb Ex tb IIIC T130°C Db IP66/68	----	0-1135A SEE NOTES A-D	135°C	10-838535(-)	

Note A: When using cables with 3 conductors or less: Amperage always limited to shell size and never greater than 1135A in any case

Note B: When using cables with 3 conductors or more: Maximum current is derated according to NEC Table 310.15(B)(3)(a).

Note C: Amperage restriction is based on single pin configuration and used for derating according to cable temperature and ambient temperature.

Note D: Connectors intended as part of a mated pair: Amperage to be derated to that of the one with a lower value.

Note E: New condition of manufacture: Connector styles shall be fitted with Fluorosilicone O-rings and Silicone gaskets for use at a low temperature.

TABLE 4: LABEL MARKING - ATEX/IECEx PRODUCT LABELING – “AR” (ARCTIC RANGE) PRODUCT							
CONNECTOR STYLE	DESCRIPTION	AMBIENT TEMP (°C)	HAZARDOUS LOCATION MARKING	ADDITIONAL MARKING FOR FIBER OPTIC MODELS (INSERT AFTER 2ND LINE OF STANDARD MARKING)	AMPERAGE RESTRICTIONS	CABLE/COND RATING (MIN TEMP)	CEMENT
13-9	90° BACKSHELL WITH EX GLAND NO CEMENT	-60 TO +40	[EPSILON MARK] II 2 G D Ex db IIC T6 Gb Ex tb IIIC T80°C Db IP66/68	----	0-259A SEE NOTES A-D	90°C	10-838535-()
		-60 TO +55	[EPSILON MARK] II 2 G D Ex db IIC T5 Gb Ex tb IIIC T95°C Db IP66/68	----	0-408A SEE NOTES A-D	90°C	10-838535-()
		-60 TO +55	[EPSILON MARK] II 2 G D Ex db IIC T4 Gb Ex tb IIIC T130°C Db IP66/68	----	0-1135A SEE NOTES A-D	135°C	10-838535-()
		-60 TO +55	[EPSILON MARK] II 2 G D Ex db IIC T3 Gb Ex tb IIIC T195°C Db IP66/68	----	0-1135A SEE NOTES A-D	135°C	10-838535-()
13-91	90° BACKSHELL NO ADAPTERS, WITH CEMENT	-60 TO +40	[EPSILON MARK] II 2 G D Ex db eb IIC T6 Gb Ex tb IIIC T80°C Db IP66/68	----	0-259A SEE NOTES A-D	90°C	10-718000-() HYSOL
		-60 TO +55	[EPSILON MARK] II 2 G D Ex db eb IIC T5 Gb Ex tb IIIC T95°C Db IP66/68	----	0-408A SEE NOTES A-D	90°C	10-838535-()
		-60 TO +55	[EPSILON MARK] II 2 G D Ex db eb IIC T4 Gb Ex tb IIIC T130°C Db IP66/68	----	0-408A SEE NOTES A-D	90°C	10-838535-()
		-60 TO +55	[EPSILON MARK] II 2 G D Ex db eb IIC T4 Gb Ex tb IIIC T195°C Db IP66/68	----	0-1135A SEE NOTES A-D	135°C	10-838535-()
Note A: When using cables with 3 conductors or less: Amperage always limited to shell size and never greater than 1135A in any case							
Note B: When using cables with 3 conductors or more: Maximum current is derated according to NEC Table 310.15(B)(3)(a).							
Note C: Amperage restriction is based on single pin configuration and used for derating according to cable temperature and ambient temperature.							
Note D: Connectors intended as part of a mated pair: Amperage to be derated to that of the one with a lower value.							

TABLE 5: LABEL MARKING - FM PRODUCT LABELING									
CONNECTOR STYLE	DESCRIPTION	AMBIENT TEMP (°C)	TEMP CLASS	HAZARDOUS LOCATION MARKING	AMPERAGE RESTRICTIONS	CABLE/COND RATING (MIN TEMP)	CEMENT		
13-2, 15-2, 17-2, 13-4, 15-4, 17-4	MECH. CLAMP W/ CEMENT OR BAS- KETWEAVE CABLE GRIPS	-40 TO +40	T6	Class I Zone 1, AEx/Ex db IIC T6 Gb Zone 21, AEx/Ex tb IIIC T85°C, Db IP68	0-259A SEE NOTES A - D	90°C	10-838535(-)		
		-40 TO +55	T5	Class I Zone 1, AEx/Ex db IIC T5 Gb Zone 21, AEx/Ex tb IIIC T100°C, Db IP68	0-408A SEE NOTES A - D	90°C	10-838535(-)		
		-40 TO +55	T4	Class I Zone 1, AEx/Ex db IIC T4 Gb Zone 21, AEx/Ex tb IIIC T135°C, Db IP68	0-1135A SEE NOTES A - D	135°C	10-838535(-)		
		-40 TO +40	T6	Class I Zone 1, AEx/Ex db IIC T6 Gb Zone 21, AEx/Ex tb IIIC T85°C, Db IP68	0-259A SEE NOTES A - D	90°C	10-838535(-)		
13-3, 15-3, 17-3	EX GLAND (NO CE-MENT)	-40 TO +55	T5	Class I Zone 1, AEx/Ex db IIC T5 Gb Zone 21, AEx/Ex tb IIIC T100°C, Db IP68	0-408A SEE NOTES A - D	90°C	10-838535(-)		
		-40 TO +55	T4	Class I Zone 1, AEx/Ex db IIC T4 Gb Zone 21, AEx/Ex tb IIIC T135°C, Db IP68	0-1135A SEE NOTES A - D	135°C	10-838535(-)		
		-40 TO +40	T6	Class I Zone 1, AEx/Ex db eb IIC T6 Gb Zone 21, AEx/Ex tb IIIC T85°C, Db IP68	0-259A SEE NOTES A - D	90°C	10-838535(-)		
17-1	17-1 PANEL MT SQ. FLANGE W/ POTTING ADAPTER AND CEMENT.	-40 TO +55	T5	Class I Zone 1, AEx/Ex db eb IIC T5 Gb Zone 21, AEx/Ex tb IIIC T100°C, Db IP68	0-408A SEE NOTES A - D	90°C	10-838535(-)		
		-40 TO +55	T4	Class I Zone 1, AEx/Ex db eb IIC T4 Gb Zone 21, AEx/Ex tb IIIC T135°C, Db IP68	0-1135A SEE NOTES A - D	135°C	10-838535(-)		
		-20 TO +40	T6	Class I Zone 1, AEx/Ex db eb IIC T6 Gb Zone 21, AEx/Ex tb IIIC T85°C, Db IP68	0-259A SEE NOTES A - D	90°C	10-718000(-) HYSOL		
18-1	18-1 CIRCULAR FLANGE W/ POT- TING ADAPTER AND CEMENT	-40 TO +55	T6	Class I Zone 1, AEx/Ex db eb IIC T5 Gb Zone 21, AEx/Ex tb IIIC T85°C, Db IP68	0-408A SEE NOTES A - D	90°C	10-838535(-)		
		-40 TO +55	T5	Class I Zone 1, AEx/Ex db eb IIC T5 Gb Zone 21, AEx/Ex tb IIIC T100°C, Db IP68	0-1135A SEE NOTES A - D	90°C	10-838535(-)		
		-40 TO +55	T4	Class I Zone 1, AEx/Ex db eb IIC T4 Gb Zone 21, AEx/Ex tb IIIC T135°C, Db IP68	0-1135A SEE NOTES A - D	135°C	10-838535(-)		

Note A: When using cables with 3 conductors or less: Amperage always limited to shell size and never greater than 1135A in any case

Note B: When using cables with 3 conductors or more: Maximum current is derated according to NEC Table 310.15(B)(3)(a).

Note C: Amperage restriction is based on single pin configuration and used for derating according to cable temperature and ambient temperature.

Note D: Connectors intended as part of a mated pair: Amperage to be derated to that of the one with a lower value.

TABLE 6: LABEL MARKING - FM PRODUCT LABELING									
CONNECTOR STYLE	DESCRIPTION	AMBIENT TEMP (°C)	TEMP CLASS	HAZARDOUS LOCATION MARKING	AMPERAGE RESTRICTIONS	CABLE/COND RATING (MIN TEMP)	CEMENT		
13-9	90° BACKSHELL WITH EX GLAND NO CEMENT	-40 TO +40	T6	Class I Zone 1, AEx/Ex db eb IIC T6 Gb Zone 21, AEx/Ex tb IIIC T85°C, Db IP68	0-259A SEE NOTES A - D	90°C	10-838535(-)		
		-40 TO +55	T5	Class I Zone 1, AEx/Ex db eb IIC T6 Gb Zone 21, AEx/Ex tb IIIC T85°C, Db IP68	0-408A SEE NOTES A - D	90°C	10-838535(-)		
		-40 TO +55	T4	Class I Zone 1, AEx/Ex db eb IIC T5 Gb Zone 21, AEx/Ex tb IIIC T100°C, Db IP68	0-1135A SEE NOTES A - D	135°C	10-838535(-)		
		-40 TO +55	T3	Class I Zone 1, AEx/Ex db eb IIC T4 Gb Zone 21, AEx/Ex tb IIIC T135°C, Db IP68	0-1135A SEE NOTES A - D	135°C	10-838535(-)		
13-91	90° BACKSHELL WITH EX GLAND NO CEMENT	-40 TO +40	T6	Class I Zone 1, AEx/Ex db eb IIC T6 Gb Zone 21, AEx/Ex tb IIIC T85°C, Db IP68	0-259A SEE NOTES A - D	90°C	10-718000(-) HYSOL		
		-40 TO +55	T5	Class I Zone 1, AEx/Ex db eb IIC T5 Gb Zone 21, AEx/Ex tb IIIC T85°C, Db IP68	0-408A SEE NOTES A - D	90°C	10-838535(-)		
		-40 TO +55	T4	Class I Zone 1, AEx/Ex db eb IIC T5 Gb Zone 21, AEx/Ex tb IIIC T100°C, Db IP68	0-1135A SEE NOTES A - D	90°C	10-838535(-)		
		-40 TO +55	T3	Class I Zone 1, AEx/Ex db eb IIC T4 Gb Zone 21, AEx/Ex tb IIIC T135°C, Db IP68	0-1135A SEE NOTES A - D	135°C	10-838535(-)		
Note A: When using cables with 3 conductors or less: Amperage always limited to shell size and never greater than 1135A in any case									
Note B: When using cables with 3 conductors or more: Maximum current is derated according to NEC Table 310.15(B)(3)(a).									
Note C: Amperage restriction is based on single pin configuration and used for derating according to cable temperature and ambient temperature.									
Note D: Connectors intended as part of a mated pair: Amperage to be derated to that of the one with a lower value.									

TABLE 7: LABEL MARKING - HERMETIC ATEX/IECEX –ARCTIC RANGE IS STANDARD PRODUCT

CONNECTOR STYLE	DESCRIPTION	AMBIENT TEMP (°C)	HAZARDOUS LOCATION MARKING	ADDITIONAL MARKING FOR FIBER OPTIC MODELS (INSERT AFTER 2ND LINE OF STANDARD MARKING)	AMPERAGE RESTRICTIONS	CABLE/COND RATING (MIN TEMP)	CEMENT
17-H	HERMETIC 17-H PANEL MT SQ. FLANGE W/ POTTING ADAPTER AND CEMENT	-60 TO +40	[EPSILON MARK] II 2 G D Ex db IIC T6 Gb Ex tb IIIC T80°C Db IP66/68	---	0-259A SEE NOTES A-D	90°C	10-838535-(-)
		-60 TO +55	[EPSILON MARK] II 2 G D Ex db IIC T5 Gb Ex tb IIIC T95°C Db IP66/68	----	0-408A SEE NOTES A-D	90°C	10-838535-(-)
		-60 TO +55	[EPSILON MARK] II 2 G D Ex db IIC T4 Gb Ex tb IIIC T130°C Db IP66/68	----	0-1135A SEE NOTES A-D	135°C	10-838535-(-)
18-H6	HERMETIC 8-H6 6 HOLE CIRCULAR FLANGE W/ POTTING ADAPTER AND CEMENT	-60 TO +40	[EPSILON MARK] II 2 G D Ex db IIC T6 Gb Ex tb IIIC T80°C Db IP66/68	----	0-259A SEE NOTES A-D	90°C	10-838535-(-)
		-60 TO +55	[EPSILON MARK] II 2 G D Ex db IIC T5 Gb Ex tb IIIC T95°C Db IP66/68	----	0-408A SEE NOTES A-D	90°C	10-838535-(-)
		-60 TO +55	[EPSILON MARK] II 2 G D Ex db IIC T4 Gb Ex tb IIIC T130°C Db IP66/68	----	0-1135A SEE NOTES A-D	135°C	10-838535-(-)
18-H8	HERMETIC 18-H8 8 HOLE CIRCULAR FLANGE W/ POTTING ADAPTER AND CEMENT	-60 TO +40	[EPSILON MARK] II 2 G D Ex db IIC T6 Gb Ex tb IIIC T80°C Db IP66/68	----	0-259A SEE NOTES A-D	90°C	10-838535-(-)
		-60 TO +55	[EPSILON MARK] II 2 G D Ex db IIC T6 Gb Ex tb IIIC T80°C Db IP66/68	----	0-408A SEE NOTES A-D	90°C	10-838535-(-)
		-60 TO +55	[EPSILON MARK] II 2 G D Ex db IIC T5 Gb Ex tb IIIC T95°C Db IP66/68	----	0-1135A SEE NOTES A-D	90°C	10-838535-(-)

Note A: When using cables with 3 conductors or less: Amperage always limited to shell size and never greater than 1135A in any case

Note B: When using cables with 3 conductors or more: Maximum current is derated according to NEC Table 310.15(B)(3)(a).

Note C: Amperage restriction is based on single pin configuration and used for derating according to cable temperature and ambient temperature.

Note D: Connectors intended as part of a mated pair: Amperage to be derated to that of the one with a lower value.

Note E: New condition of manufacture: Connector styles shall be fitted with Fluorosilicone O-rings and Silicone gaskets for use at a low temperature.

TABLE 8: FM APPROVAL HERMETIC EX LABELING									
CONNECTOR STYLE	DESCRIPTION	AMBIENT TEMP (°C)	TEMP CLASS	HAZARDOUS LOCATION MARKING	AMPERAGE RESTRICTIONS	CABLE/COND RATING (MIN TEMP)	CEMENT		
17-H	17-H PANEL MT SQ. FLANGE W/ POTTING ADAPTER AND CEMENT	-50 TO +40	T6	Class I Zone 1, AEx/Ex db IIC T6 Gb Zone 21, AEx/Ex tb IIIC T85°C, Db IP68	0-259A SEE NOTES A - D	90°C	10-838535-()		
		-50 TO +55	T5	Class I Zone 1, AEx/Ex db IIC T5 Gb Zone 21, AEx/Ex tb IIIC T100°C, Db IP68	0-408A SEE NOTES A - D	90°C	10-838535-()		
		-50 TO +55	T4	Class I Zone 1, AEx/Ex db IIC T4 Gb Zone 21, AEx/Ex tb IIIC T135°C, Db IP68	0-1135A SEE NOTES A - D	135°C	10-838535-()		
18-H6	18-H6 6 HOLE CIRCULAR FLANGE W/ POTTING ADAPTER AND CEMENT	-50 TO +40	T6	Class I Zone 1, AEx/Ex db eb IIC T6 Gb Zone 21, AEx/Ex tb IIIC T85°C, Db IP68	0-259A SEE NOTES A - D	90°C	10-838535-()		
		-50 TO +55	T5	Class I Zone 1, AEx/Ex db eb IIC T5 Gb Zone 21, AEx/Ex tb IIIC T100°C, Db IP68	0-408A SEE NOTES A - D	90°C	10-838535-()		
		-50 TO +55	T4	Class I Zone 1, AEx/Ex db eb IIC T4 Gb Zone 21, AEx/Ex tb IIIC T135°C, Db IP68	0-1135A SEE NOTES A - D	135°C	10-838535-()		
18-H8	18-H8 8 HOLE CIRCULAR FLANGE W/ POTTING ADAPTER AND CEMENT	-50 TO +40	T6	Class I Zone 1, AEx/Ex db eb IIC T6 Gb Zone 21, AEx/Ex tb IIIC T85°C, Db IP68	0-259A SEE NOTES A - D	90°C	10-838535-()		
		-50 TO +55	T5	Class I Zone 1, AEx/Ex db eb IIC T5 Gb Zone 21, AEx/Ex tb IIIC T100°C, Db IP68	0-408A SEE NOTES A - D	90°C	10-838535-()		
		-50 TO +55	T4	Class I Zone 1, AEx/Ex db eb IIC T4 Gb Zone 21, AEx/Ex tb IIIC T135°C, Db IP68	0-1135A SEE NOTES A - D	135°C	10-838535-()		
Note A: When using cables with 3 conductors or less: Amperage always limited to shell size and never greater than 1135A in any case									
Note B: When using cables with 3 conductors or more: Maximum current is derated according to NEC Table 310.15(B)(3)(a).									
Note C: Amperage restriction is based on single pin configuration and used for derating according to cable temperature and ambient temperature.									
Note D: Connectors intended as part of a mated pair: Amperage to be derated to that of the one with a lower value.									
Note E: New condition of manufacture: connector styles shall be fitted with Fluorosilicone O-rings and Silicone gaskets for use at a low temperature.									

FM Approved, Product Labeling Information
Information below must be attached to connectors via non-removable label.

Amphenol
Sidney NY 13838 USA
Star-Line, Size Ref
Work Order Number; Date Code; Facility Code
"Max volts, Max amp, Current rating per pin"



DO NOT SEPARATE WHEN ENERGIZED

- **Identification markings for all connectors refer to Label chart on Page 8 & 9.**

All FM approved product must have warning marks in both, English and French, as follows:

"Do not open when an explosive gas or dust is present. Do not separate while energized. Supply conductors shall be suitable for a continuous operating temperature of at least 90°C."

"Ne pas ouvrir en présence de gaz explosive ni en atmosphère de poussière. A ne pas séparé si énérgisé Les conducteurs d'alimentation doivent etre suffisant pour une température constant de 90°C."

The following instructions apply to equipment covered by certificate numbers:

ATEX Certificate & IECEx Certificate

The equipment may be used with flammable gases and vapours with apparatus group(s) IIA, IIB, & IIC and with temperature classes T6, T5, & T4.

The equipment is only certified for use in ambient temperatures in the range -40°C to +55°C (see table page 5) and for "AR" Arctic Range -60°C to + 55°C (see tables page 6 & 7) and should not be used outside this range.

The product complies with the following standards:

Installation shall be carried out by suitably-trained personnel in accordance with the applicable code of practice **e.g.**

EN60079-0 (IEC60079-0)	Explosive atmospheres – Part 0: Equipment - General requirements
EN 60079-1 (IEC60079-1)	Explosive atmospheres - Part 1: Equipment protection by flameproof enclosures "d"
EN 60079-7 (IEC60079-7)	Explosive atmospheres – Part 7: Equipment protection by increased safety "e"
EN 60079-28 (IEC60079-28)	Protection of equipment and transmission systems using optical radiation
EN 60079-31 (IEC60079-31)	Equipment dust ignition protection by enclosure "t"

EN/IEC 60079-14 or EN/IEC 61241-14. It is the end user's responsibility to ensure that the product, as specified and confirmed by the product label, is suitable for its intended application.

Inspection and maintenance of this equipment shall be carried out by suitably trained personnel in accordance with the applicable code of practice e.g. **EN/IEC 60079-17 or EN/IEC 61241-17.**

Repair of this equipment shall be carried out by suitably trained personnel in accordance with the applicable code of practice e.g. **EN/IEC 60079-19.**

Components to be incorporated into or used as replacement parts of the equipment shall be fitted by suitably trained personnel, using only components purchased from Amphenol or an Amphenol approved distributor. Any use of non-approved components/suppliers will invalidate the certification for that product.

The certification of this equipment relies upon the following materials used in its construction:

1. Connector Materials:

- (Standard Base Material) ASTM B211 or B221 Alloy 6061-T6, Aluminum,
- (Optional Base Material) ASTM 5640, Alloy 303, Stainless Steel,
- (Optional Base Material) ASTM B455, Alloy C38500, Brass.

2. Seal Materials:

- Fluorosilicone w/ Durometer of 70 SHORE A, 90 SHORE A
- Buna Rubber w/ Durometer of 70 SHORE A.
- Low Temp Silicone w/ Durometer of 50 SHORE A
- Buna Rubber w/ Durometer of 50 SHORE A.

If the equipment is likely to come into contact with aggressive substances, then it is the responsibility of the user to take suitable precautions that prevent it from being adversely affected, thus ensuring that the type of protection provided by the equipment is not compromised.

Aggressive substances: e.g. acidic liquids or gases that may attack metals, or solvents that may affect polymeric materials.

Suitable precautions: e.g. regular checks as part of routine inspections or establishing from the material's data sheets that it is resistant to specific chemical.

Service life – Contact mating life is in excess of 500 cycles. Bore and spigot flamepaths between plug and receptacle are outlined in these assembly instructions. Dimensions should be checked periodically, as determined by equipment owner's maintenance schedule, for similar devices. If dimensions are found out of tolerance, product should be replaced. Product is not serviceable, by manufacturer, or end-user.

Product should be kept within original packaging until time of installation. Storage temperature should be maintained between +5-25°C, at a humidity below 70%, and away from direct sources of heat. Under these conditions, product has a shelf life of 48 months from date of manufacture. Epoxies must be stored at 20-25°C, and have a shelf-life marked on the epoxy packaging.

Product that has been determined to have reached end-of-life, can be removed from equipment and disassembled for recycling. Components that are not accepted by recycler, are safe to be disposed of with other commercial waste. This includes any two part epoxies, supplied with the product, as long as they are mixed per instructions, and fully Cured.

SPECIAL CONDITIONS FOR SAFE USE (denoted by X after the certificate number)

- The EX-17 & EX-18 panel mounted variants may be installed in suitably certified and dimensioned flameproof equipment providing that the certification of this flameproof equipment will allow such installation. They have the following dimensioned spigot joints and are suitable for Group IIA, IIB, or IIC, dependent on the associated apparatus entry dimensions.

Shell Size	Spigot diameter (mm)	Spigot length (mm)
12	39.90/39.85	46 (+/-1)
16	49.90/49.85	46 (+/-1)
20	62.90/62.85	46 (+/-1)
24	74.90/74.85	46 (+/-1)
28	89.90/89.85	46 (+/-1)

- The panel mounted variants may be fitted in an increased safety enclosure when the free internal space is filled with epoxy resin and providing the certification of the enclosure will allow such installation. An electric strength test in accordance with EN 60079-7 Clause 7.1 will be performed on each unit after installation of the epoxy resin.
- These devices shall not exceed the temperature values on the associated enclosure as detailed in the "LABEL MARKING - SIRA PRODUCT LABELING - ATEX/IECEX" table detailed on page 5.

Connector Style	Cement	Colour (Mixed)	Temperature Range (°C)
13-2, 15-2, 17-2, 13-4, 15-4, 17-4, 13-3, 15-3, 17-1, 17-3, 18-1	Resin 50-3150FR/Cat 190	Black	-60 to +135
18-1	Hysol ES1002	Grey	-20 to +70

- The Ex-18 range connector does not incorporate an external earth facility. It is the responsibility of the user or installer to ensure adequate earth continuity by means of guidance given within the manufacturer's installation instructions.
- When connectors to this certificate marked as Ex 'op is' are used, the source of the fibre optic radiation shall be suitably certified as compliant with EN 60079-28/IEC 60079-28 and shall provide an optical source in compliance with the following parameters:

T6 & T80°C (Tamb +40°C)	T4 & T130°C (Tamb +55°C)
Fibre optic source limited to a maximum signal power of 15 mW and a maximum irradiance of 5 mW/mm ² (surface area not exceeding 400 mm ²).	Fibre optic source limited to a maximum signal power of 35 mW and a maximum irradiance of 5 mW/mm ² (surface area not exceeding 400 mm ²).

- When connectors to this certificate marked as Ex 'op pr' are used, the connectors are only to be attached to an Ex db IIC Gb certified enclosure, suitable for the assigned ambient temperatures.
- In the case where Ex 'op pr' EPL 'Gb' certified connectors are attached to certified Ex 'db' enclosures, the Ex 'op is' power limitations for optical sources do not apply.
- In the case where two Ex 'op pr' EPL 'Gb' certified connectors are connected together as an inline mated pair, the Ex 'op is' power limitations for optical sources do not apply.
- Connectors certified as Ex 'tb' EPL 'Db' must in all cases comply with the power limitations for Ex 'op is' optical sources.

Star-Line EX®
Assembly & Terminating Instructions
Cable Jacket and Wire Stripping Details

Shell Size	Contact Size AWG(mm)	Mod 1 (Solder Contact) Strip Lengths (mm)		Mod 1 (Pressure Contact) Strip Lengths (mm)		Mod 2 & 3 (Crimp Contact) Strip Lengths (mm)	
		Conductor	Jacket	Conductor	Jacket	Conductor	Jacket
12	18 (0.75mm)	7.2mm	99.2mm	-	90.5mm	11.5mm	90.5mm
	16 (1.5mm)	7.2mm	99.2mm	-	90.5mm	14.6mm	90.5mm
	12 (4.0mm)	8.7mm	99.2mm	17.5mm	90.5mm	15.5mm	90.5mm
	10 (6.0mm)	11.9mm	99.2mm	14.3mm	84.1mm	17.1mm	92.1mm
16	18 (0.75mm)	7.2mm	105.5mm	-	96.8mm	11.5mm	96.8mm
	16 (1.5mm)	7.2mm	105.5mm	-	96.8mm	14.6mm	96.8mm
	12 (4.0mm)	8.7mm	105.5mm	-	96.8mm	15.5mm	96.8mm
	10 (6.0mm)	11.9mm	105.5mm	-	90.5mm	17.1mm	98.4mm
	8 (10.0mm)	15.1mm	105.5mm	-	88.9mm	21.0mm	98.4mm
	4 (25.0mm)	16.7mm	105.5mm	17.5mm	87.3mm	23.0mm	101.6mm
20	18 (0.75mm)	7.2mm	118.2mm	-	109.5mm	11.5mm	109.6mm
	16 (1.5mm)	7.2mm	118.2mm	-	109.5mm	14.6mm	109.6mm
	12 (4.0mm)	8.7mm	118.2mm	-	109.5mm	15.5mm	109.6mm
	10 (6.0mm)	11.9mm	118.2mm	-	103.2mm	17.1mm	111.12mm
	8 (10.0mm)	15.1mm	118.2mm	-	101.6mm	21.0mm	111.12mm
	4 (25.0mm)	16.7mm	118.2mm	17.5mm	101.6mm	23.0mm	113.9mm
	1/0 (50.0mm)	18.3mm	118.2mm	19.1mm	98.4mm	31.0mm	115.2mm
	535MCM (240mm)	50.0mm	118.2mm	-	90.0mm	-	-
24/C24	18 (0.75mm)	7.2mm	130.9mm	-	122.2mm	11.5mm	-
	16 (1.5mm)	7.2mm	130.9mm	-	122.2mm	14.6mm	-
	12 (4.0mm)	8.7mm	130.9mm	-	122.2mm	15.5mm	-
	10 (6.0mm)	11.9mm	130.9mm	-	115.9mm	17.1mm	-
	8 (10.0mm)	15.1mm	130.9mm	-	114.3mm	21.0mm	-
	4 (25.0mm)	16.7mm	130.9mm	17.5mm	100.0mm	23.0mm	-
	1/0 (50mm)	18.3mm	130.9mm	19.1mm	117.5mm	31.0mm	-
	4/0 (120mm)	18.3mm	130.9mm	19.1mm	127.0mm	31.6mm	-
	535 MCM (240mm)	50.0mm	130.9mm	-	90.0mm	-	-
	777 MCM (400mm)	50.0mm	130.9mm	-	90.0mm	-	-
28/C28	18 (0.75mm)	7.2mm	137.3mm	-	125.6mm	11.5mm	-
	16 (1.5mm)	7.2mm	137.3mm	-	125.6mm	14.6mm	-
	12 (4.0mm)	8.7mm	137.3mm	-	125.6mm	15.5mm	-
	10 (6.0mm)	11.9mm	137.3mm	-	122.2mm	17.1mm	-
	8 (10.0mm)	15.1mm	137.3mm	-	120.7mm	21.0mm	-
	4 (25.0mm)	16.7mm	137.3mm	17.5mm	106.4mm	23.0mm	-
	1/0 (50mm)	18.3mm	137.3mm	19.1mm	123.8mm	31.0mm	-
	4/0 (120mm)	18.3mm	137.3mm	19.1mm	133.4mm	31.6mm	-
	350 MCM (185mm)	21.4mm	137.3mm	-	130.1mm	33.5mm	-

Star-Line EX[®] Assembly & Terminating Instructions

The table at right, gives the wire size and cord/cable types to be used with the Star-line EX plugs, receptacle and cable connectors. The plugs and cable connectors are intended for connection to 3,4 or 5 conductor cord/cables depending on the contact insert configuration.

The cord sealing grips range for plugs and cord connectors is 1/8". For instance, if inside diameter of grommet is 3/4" it will seal and grip a cord diameters in the range of 0.750" diameter max, to 0.625" minimum. Inside diameter of grommets are in sixteenth of an inch increments.

There are two types of contacts used in Mod I style inserts, one is solder, the other is pressure. The pressure contacts apply termination force via a set screw, and require being torque to values provided in the table below:

Ampere Rating of Device	Conductor Size	Cord/Cable Type
20	#14	S, SO
30	#12, #10	S, SO
60	#6, #4	W
100	#0, #1, #2	W
200	3/0, 4/0	W

Torque	20 amp #12 contact	30 amp #10 contact	40 amp #8 contact	60 amp #4 contact	100 amp 1/0 contact	200 amp #4/0 contact
in-lb	N/A	15	25	20	50	100
N-m	N/A	1.7	2.8	2.3	5.7	11.3

Regarding the use of threadlocker: Employment of threadlocker is suggested in environments where vibration or external torsional influences are anticipated. Its use is certified on all threaded joints and fasteners, including the flamepaths on plug/receptacle accessory threads, and on cable adapter gland threads. Loctite 242 (blue, non- permanent) or equivalent, is recommended, as it allows re-entry into the connector assembly, for the purpose of repair and/or inspection. Usage: Apply several drops of the product onto the male thread at the female engagement area, mate the threads, and tighten, as required.

A. Prepare end of cable by stripping jacket and insulation per tables shown on previous page. Remove any ridges or grooves by scarfing the edges to provide a smooth surface on the cable to insure good grommet sealing. Tin conductors to be soldered to within 1/16" of insulation. Use only resin flux for all soldering.

B. Slide the EX gland nut, cable grip, or anti-friction washer, grommet and cable adapter, over the cable in the order named. Be sure the right size EX gland or grommet has been selected to obtain a proper seal. See photo "YY".

C. Solder conductors in contacts, if solder type. TO ENSURE ENVIRONMENTAL SEALING, ALL CONTACTS MUST REMAIN IN PLACE EVEN IF EVERY ONE IS NOT BEING USED. The silicone insulation is heat resistant, but reasonable care must be exercised to prevent unnecessary heating. It is recommended that a DC induction soldering unit be used if possible. Do not use open flame soldering. It is recommended that heat shrink be applied over finished termination point.

D. Support the barrel assembly in a vise having smooth-faced jaws; with female receptacle have flange secured in vice for holding steady. The plug and receptacle keyways/keys are designed to withstand the assembly torque. See photo "MM". If employed, apply threadlocker, to male threads.

E. Install cable adaptor or insulation clamp nut by strap wrench, turning counterclockwise (left hand thread) until hand-tight. APPLY STRAP WRENCH TO CABLE ADAPTER OR INSULATION CLAMP AND TIGHTEN UNTIL IT SHOULD FULLY ON BARREL. Substantial resistance should be felt by assembler as he rotates adapter on final revolution. See photo "PP". If employed, apply threadlocker, to gland threads.

F. Slide EX gland or grommet into cable adapter and engage either cable grip, or gland washer and gland nut. DRAW UP TIGHT WITH WRENCH. If mechanical clamp nut is used, tighten clamp screws as the final step.

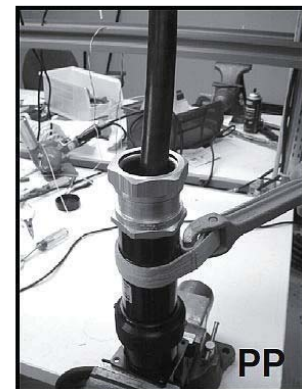

Note: Photo "YY" is an example of EX-13-3 Series Plug employing an IECEx certified gland

Star-Line EX[®] Assembly Instructions for 90° Backshell Plug

- A)** Disassembly Ex cable gland into two parts, Assembly "A" and Assembly "B".
- B)** Remove armor cone and armor ring from Assembly "B".
- C)** Slide Assembly "B", armor ring, and armor cone onto cable in the order named.
- D)** Hand tighten Assembly "A" onto bottom of 90° Housing.
- E)** Prepare end of cable by stripping jacket and insulation per tables shown on previous page. Remove any ridges or grooves by scarfing the edges to provide a smooth surface on the cable to insure good grommet sealing.
- F)** Push stripped conductor bundle through Assembly "A" and into 90° housing and out through the front of housing.
- G)** Terminate cable armor onto armored gland per gland manufacturer's instruction.
- H)** Crimp conductors onto contacts according to contact configuration layout.
- I)** Push contacts into already assembled insert, according to contact configuration layout.
- J)** Tighten up insert energizing sleeve, and push front barrel assembly onto housing. Tighten to housing using 4x M6 bolts.

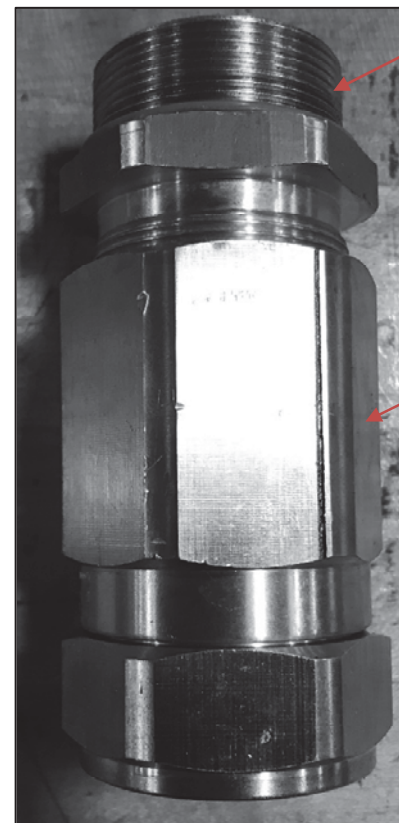

Star-Line EX® Connector Mating, Securement and Certification Compliance

The Starline EX series utilizes a traditional threaded (ACME) coupling scheme, with an additional enhancement. The coupling sleeve is part of an actual assembly. The assembly is comprised of a coupling sleeve, and two (2) grub screws (set screws). These set screws and their proper implementation, are a requirement of the Certificate of Conformity.

Once the connectors are mated, and the coupling nut has been tightened, it is a requirement that the Grub Screws both be tightened using a proper tool (allen key; supplied with connector). This prevents the coupling nut from backing off, and minimizes “unauthorized decoupling” of the mated connector pair. The Grub Screws would have to be intentionally loosened, in order for the coupling nut to be retracted, and the connectors unmated.

WARNING: Compliance with the Certificate of Conformity is satisfied when:

- 1) the male and female connectors are completely mated, and
- 2) the coupling sleeve is fully engaged, and
- 3) the grub screws are fully engaged, and
- 4) all the above are established before the circuit is energized.

WARNING: When circuits are de-energized, and the connectors, all plugs and receptacles, are unmated, the respective flameproof blanking caps must be installed, and all grub screws secured. Flameproof blanking caps are a part of the certification, and their use is required, to maintain flameproof worthiness of the connector halves independently, should the circuit be inadvertently re-energized.

Star-Line EX® Assembly & Terminating Instructions For Electrical Connectors with MOD II Inserts

Individual contacts are crimped to their respective conductors outside of the connector where ample working space is available. The crimping operation can be done by hand or power operated tools. Consult Amphenol Catalog 12-054 for proper tool information.

Terminated contacts are individually inserted into the connector insulation with a contact insertion tool. See photo “JJ”. Contacts may be inserted and removed without degrading contact retention or environmental capability. The front rigid portion of the insert functions to stabilize and ensure positive alignment of the contacts.

Contact cavities are clearly numbered on the front and rear insert face to facilitate identification during assembly, inspection, and maintenance.

All contact cavities, whether used or not, **must be populated** in order to maintain certification and proper environmental sealing.

Note: Go to AOGT 2TO1 drawing for additional instructions when terminating 2 Conductors into 1 Power contact



Star-Line EX® Assembly & Terminating Instructions For Electrical Connectors with MOD III Inserts

Mod III connectors contain insulations that are factory installed and locked into position with a non-removable retaining ring. Each insulator assembly contains a resilient seal interposed between two rigid plastic insulators. Mod III contacts are rear insert-able and rear release-able for quick and easy circuit changes. Mod III contacts are retained in their respective cavities by means of collapsible metal collets. The main advantage of collet style retention are lower insertion forces, eliminating need for insertion tools, and higher retention forces. Contact cavities are clearly numbered on the front and rear insert face to facilitate identification during assembly, inspection, and maintenance. All contact cavities, whether used or not, **must be populated** in order to maintain certification and proper environmental sealing.

All connectors are shipped with the inserts factory installed in the barrel shell, and in the specified key position.

CRIMPING CONTACTS: Contacts are crimped outside of the connector with a proper tool. Check through the inspection hole in contact to make certain wires are fully bottomed in well before crimping.

Star-Line EX[®] Assembly & Terminating Instructions Panel Mounting a Receptacle

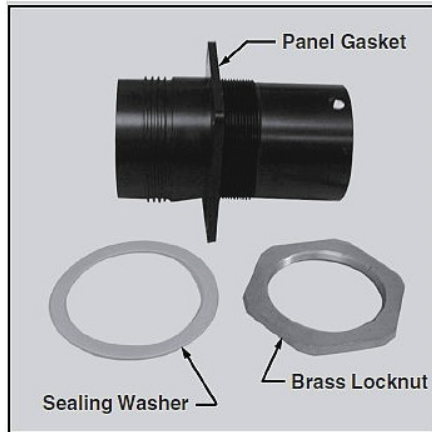

1. The panel mount variant shall be installed onto suitably certified and dimensioned flameproof equipment when its certificate allows such installation.
2. The panel receptacle is comprised of two basic pieces. The first is the actual panel receptacle assembly, where the mating plug enters, and the second is the panel adapter/potting chamber.
3. Following the termination and/or insertion of the contacts into their representative cavities, apply several drops of thread locking compound (Loctite 242, blue, or equal), to the male threads of the receptacle shell. Using a strap wrench, thread the panel adapter / potting chamber firmly to the shoulder of the receptacle, until travel ceases.
4. The potting step can now be applied. After the potting compound has cured, the completed receptacle assembly can be installed into the enclosure as follows:

For Ex"db eb" panel applications:

Use a flat panel gasket, and jam nut.

- A) As is typical in all gasketing applications, clean all mating surfaces:
- Back of flange
 - Front and back mating surfaces of panel
 - Faces of gasket
 - Mating face of jam nut
- B) Mount gasket to back of connector flange.
- C) Install connector through panel, positioning as required
- D) Install washer as required at back of panel onto connector
- E) Install and run jam nut to panel
- F) Tighten jam nut fully, by hand, so the connector is solidly pressed against the panel and the gasket is captured.
- G) To complete tightening, turn the jam nut an additional 1/4 turn using an appropriate tool.
- H) In applications where vibration is anticipated, a second jam nut should be used to lock the primary jam nut in place.
- I) Thread locking compound (Loctite 242, blue, or equal), per the compound suppliers recommendations, can be used on any of the threads with- out impacting flamepath function.

finished assembly.

For Ex"db" bulkhead applications:

- The panel adapter/potting chamber has external threads that are flamepath ready. Ex"db" applications require an enclosure that is Ex"db" rated. For this case, the included o-ring is used, and the flat gasket is omitted.
- A) With the o-ring installed onto the back of the receptacle flange, thread the receptacle assembly into the mating flameproof thread on EX"db" approved enclosure. The thread on the enclosure shall be identified as a threaded flamepath, and suitable to accept either EX certified cable glands or Starline EX connectors.
- B) Thread the connector into the bulkhead by hand, stopping at the point where the o-ring just touches down onto the bulkhead surface.
- C) Turn the connector an addition amount so that the mounting holes in the flange, line up with the blind threaded holes in the enclosure. If after touching down the o-ring, the holes happen to line up with less than a 1/4 turn, advance the receptacle until the next holes line up.
- D) Secure the connector to the enclosure using M5 fasteners.

For all increased safety panel mount receptacles:
In accordance with EN/IEC 60079-7, Clause 7.1, the increased safety enclosure certificate must include the use of the device as well as an electric strength test on

Star-Line EX[®]
Assembly & Terminating Instructions
Panel Mounting a Receptacle

EX"db eb" Panel Cutout Details

Amphenol Starline EX Series

Sheet Metal Enclosure Hole Dimension for Panel Mount Receptacle (Ex "db eb"). Hole sizes are required to maintain IP66 assurances.

Size	Adapter Thread		Recommended Hole Size	
	mm	inch	mm +/-0.5	inch +/-0.020"
12	40	1.575	41	1.614
16	50	1.969	51	2.008
20	63	2.480	64	2.520
24	75	2.953	76	2.992
28	90	3.543	91	3.583

Hole Sizes for EX "eb" applications using flat die-cut gaskets (provided) and jam nuts

Star-Line EX® Potting Instructions for burst pouch

All cable adapters, other than ones suited for mating with an EX-certified gland, must be filled with cement (potted). The materials exclusively certified for use in filling this connector line are listed on page 5 of these instructions. The user or installer shall consider the performance of these materials with regard to attack by aggressive substances that may be present in the hazardous area. This material is a two-component casting system with a pre-determined ratio (by weight). It has low exothermic qualities during cure. The material starts to harden in under 4 hours and fully cures at room temperature in 24. The product is available in pre-measured 'burst pouches'.

More information is available by contacting:

Amphenol Industrial Operations, Technical Support
Phone: (520) 285-5130

Filling Depths

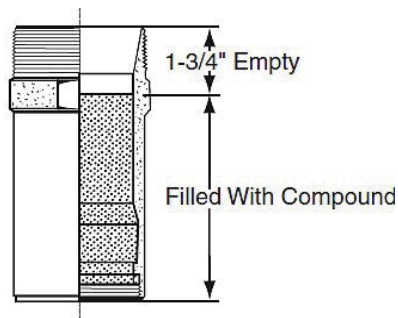

Cable Adapter (shown above)

In-line cable adapters are filled to within one & three quarter inches (1¾") of the end of the adapter. The goal is to have all the volume filled without interrupting the cable grommet from seating when the strain relief nut is installed.

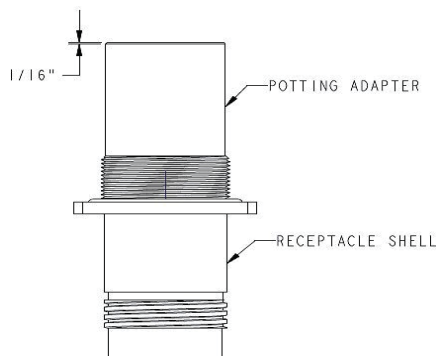

Panel Adapter (shown above)

Bulkhead adapters should be filled to within 1/16" of the top.

Mixing Instructions

1. CAUTION: Wear goggles or other eye protection during all operations.
2. Read "Recommendations while potting" on next page.
3. Follow burst pouch mixing instructions illustrated below.
4. Fill connectors in mated condition to assure contact alignment during cure.
5. Potting not required when using Exd gland option for plugs and in-line receptacles.

BURST POUCH MIXING INSTRUCTIONS



1. Roll pouch toward burst seal.

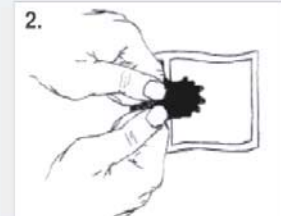

2. Apply thumb pressure to rupture burst seal.

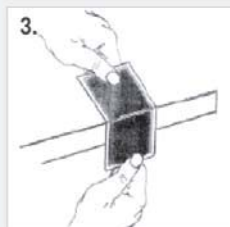

3. Mix thoroughly on table edge or any 90 degree surface until well mixed.

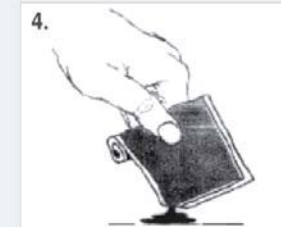

4. Cut corner and dispense.

To ensure proper adhesion of the potting compound to all components of the connector, the inner body of the connect- or, wires, boot, and all other materials that will contact the compounds must be clean and free of any trace of grease, oil, wax, alodyne, anodizing, or other contaminants. Any contaminated surface shall be cleaned by using a small stiff-bristled brush and an electrical approved solvent.

Star-Line EX[®] Potting Instructions for cartridges

All cable adapters, other than ones suited for mating with an EX-certified gland, must be filled with encapsulant (potted). The material exclusively certified for use in filling this connector line is Amphenol Industrial part number 10-838535. The user or installer shall consider the performance of these materials with regard to attack by aggressive substances that may be present in the hazardous area. This material is a two-component casting system with a 1:1 volumetric mix ratio. It has low exothermic qualities, peaking at only 102°F during cure. The material starts to harden in under 2 hours and fully cures at room temperature in 24. It can be quick cured in 2 hours at 140°F.

The product is available in easy "mix & dispense" cartridges. More information is available by contacting:

Amphenol Industrial Operations, Technical Support
Phone: (520) 285-5130

Filling Depths

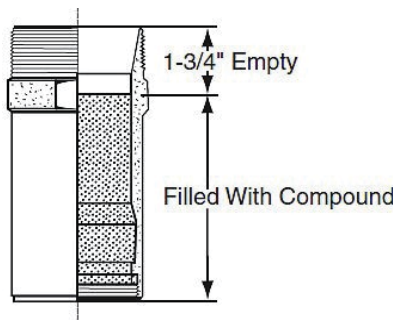

Cable Adapter (shown above)

In-line cable adapters are filled to within one & three quarter inches (1 $\frac{3}{4}$ ") of the end of the adapter. The goal is to have all the volume filled without interrupting the cable grommet from seating when the strain relief nut is installed.

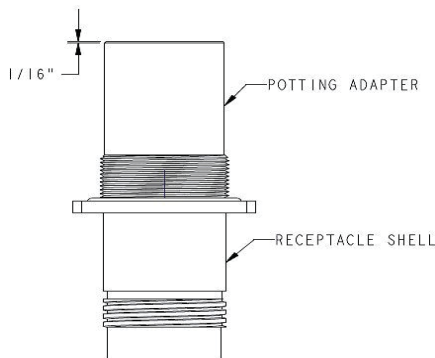

Panel Adapter (shown above)

Bulkhead adapters should be filled to within 1/16" of the top.

Mixing Instructions

1. CAUTION: Wear goggles or other eye protection during all operations.
2. Remove the tape band from the mid-section of the cartridge.
3. Squeeze cartridge slightly in area of the removed tape band to deform foil barrier.
4. Push the threaded end of the mixing rod into small and fully threaded into its mating thread within the tube.
5. Push the mixing rod to the bottom of cartridge and begin plunging the mixing rod, the full length of the cartridge, while rotating the mixing rod approximately 90° with each stroke. Mix for the total number of 50 strokes. A stroke is one complete in and out cycle. On the last stroke, mixing rod should be fully extended outward.
6. Grasp the cartridge firmly at the neck of the tube, and unscrew the mixing rod by turning counterclockwise approximately 3 turns. Remove mixing rod.
7. Install nozzle and remove bottom cap.
8. Load tube into a standard painters caulk gun.
9. Pot connectors in mated condition to assure contact alignment.
10. Potting not required when using Exd/Exe gland option for plugs and in-line receptacles.

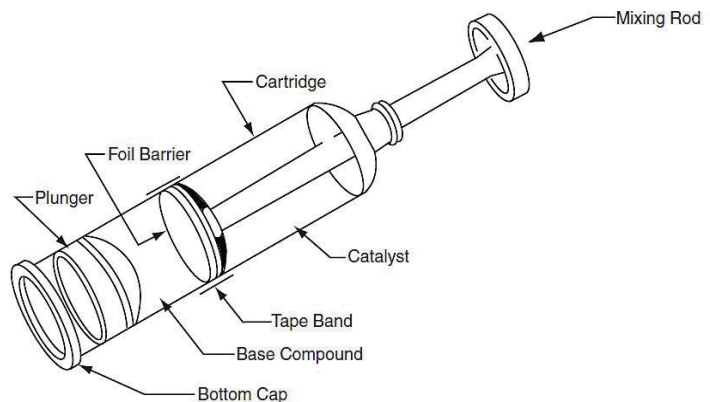

Recommendations while potting

It is recommended that when mated sets of connectors are potted that the connector with the female insert be potted first, allowed to set and then the male be potted while it is mated to the previously potted female connector. This will ensure that the male contacts will be seated or 'aimed' properly at the female socket contact opposite it. The male contacts have a given amount of movement while not engaged, and if during initial potting procedures the male contacts are positioned beyond this movement range, they will not properly engage with the socket contact.

Star-Line EX[®] Potting Instructions Volume Chart

The following chart illustrates how much potting compound is needed per connector. This is based on fill lengths of 3-7/8" (in-line adapters) and 1-3/4" (Panel mount adapters) and the smallest allowable cable diameter included for each particular shell.

* Note: These volumes are estimated. Necessary volumes may vary depending on conductor count, insulation, and jacket thickness.

Shell Size	Approx. Cement usage in a 6" cable adapter	Approx. Cement usage in a bulkhead adapter
12	1.6 oz.	0.5 oz.
16	3.5 oz	1.1 oz.
20	6.1 oz	2.1 oz.
24	9.0 oz	3.3 oz
28	11.1 oz	4.5 oz

Routine Dielectric Tests

NOTE: Connectors that are "kitted" are not subject to Routine Dielectric Testing. Any connector that is terminated, populated, and assembled to cable, shall be subject to the Dielectric Testing as noted below.

All terminated connector assemblies, (100% of production), that are marked AEx/Ex de, shall be subjected to an a.c. potential equal to $2(E) + 1000$ volts [or with a d.c. potential of $1.4(2E + 1000)$ volts], applied between the connector and conductors and between individual conductors, for at least one minute, where 'E' equals the rated voltage.

As an alternative to these tests, the assemblies may be subjected to a potential equal to 1.2 times the test voltages determined above for at least 100 ms.

WARNING: The dielectric test required may present a hazard of injury to personnel and/or property and should only be performed under controlled conditions and by persons knowledgeable of the potential hazards of such testing to minimize the likelihood of shock and/or fire.

